

REVISIONS				
ZONE	REV.	DESCRIPTION	DATE	APPROVED
	1	TO UPDATE PERFORMANCE	4/8/2013	CR

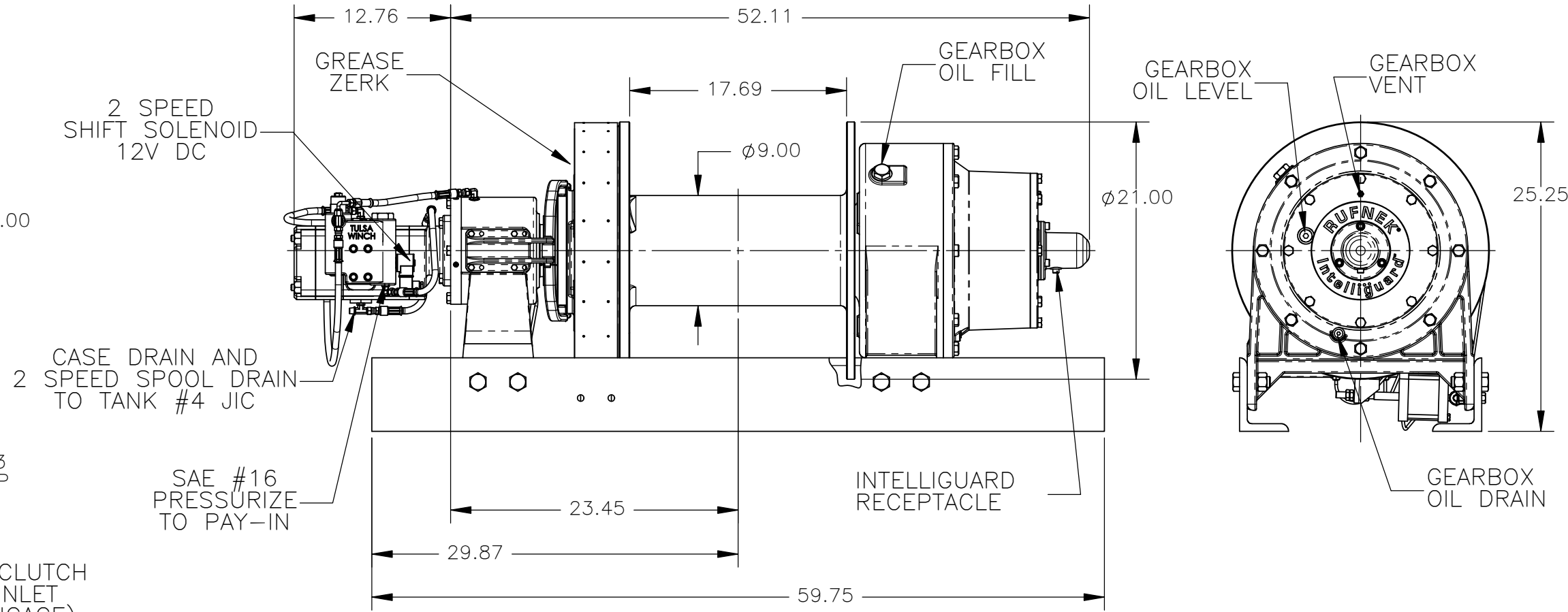
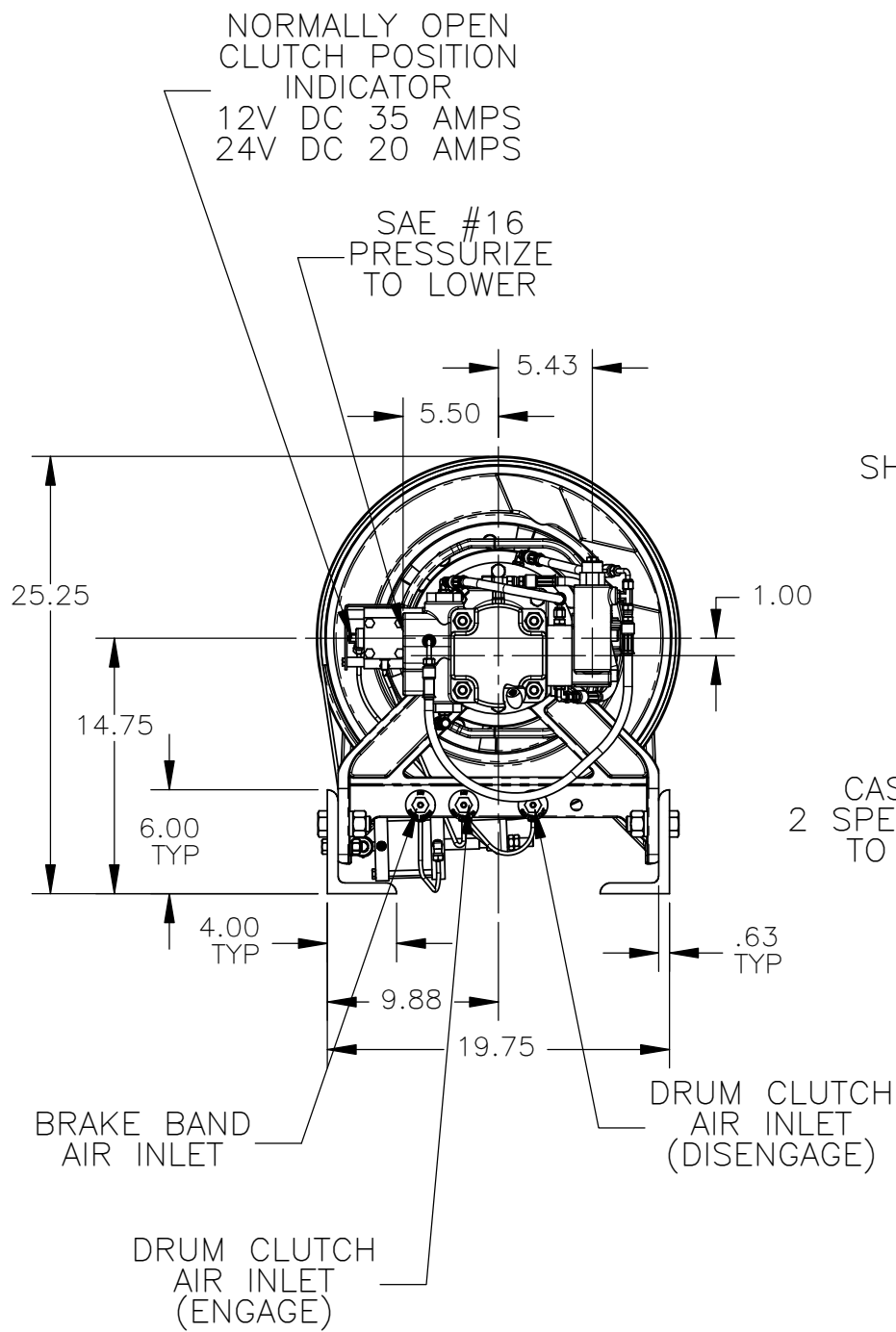

- NOTES:
1. GEARBOX FILLED WITH MOBILUBE SHC75W-90. (9 QTS)
 2. THE BRAKE IS LUBRICATED & COOLED WITH THE OIL IN THE GEARBOX.
 3. UNIT PRIMED WITH GRAY PRIMER.
 4. INTELLIGUARD SYSTEM SHIPPED WITH WINCH.

WINCH PERFORMANCE SPECIFICATIONS

PRESSURE: 2,700 PSI		CABLE DIA.: 1.00"			
	WINCH PERFORMANCE LOW SPEED 60 GPM		WINCH PERFORMANCE HIGH SPEED 60 GPM		TOTAL DRUM CAPACITY (FT)
LAYER	STALL LINE PULL (LBS)	WINCH SPEED (FPM)	STALL LINE PULL (LBS)	WINCH SPEED (FPM)	
FIRST	80,000	26	36,400	58	45
SECOND	66,762	32	30,333	69	98
THIRD	57,224	37	26,000	81	160
FOURTH	50,071	42	22,750	93	231
FIFTH	44,508	47	20,222	104	312

UNLESS OTHERWISE SPECIFIED

- All dimensions are in inches
- Inside corner radii .03"
- Outside chamfer .03 X 45°
- Remove all burrs, break sharp edges
- Fastener torque per EN11000

Tolerances: Fractions ±1/32 Angles ±1/2°
3 Place Decimal ±.010 Concentricity .010 TIR
2 Place Decimal ±.030 Machine Finish 125✓

DO NOT SCALE DRAWING

DRAWN BY: DB DATE: 08-18-12
APPD. BY: DATE:

This drawing is the property of TWG. Reproduction or the divulging of data hereon is not permitted without specific approval of TWG.



RN80P INSTALLATION

B MATERIAL DRAWING NO. **I82021008** REV 1

WT 1,585 LBS HEAT TREAT SHEET